

# Wastegates/External Wastegate

## Gen-V WG45 Hyper-Gate45



The Gen-V WG45 Hypergate45 external wastegate is a cost effective, high performing 45mm external wastegate. The Gen-V provides extensive user configurability, world leading extended thermal performance, fatigue resistance and best in class flow performance for optimum control and longevity.

- Liquid cooling provision
- Strap type V-band clamps
- User adjustable actuator position
- Modular actuator design
- Motorsport / Compressed Gas configurations available

### MECHANICAL DATA

Valve diameter	45mm
Mass	1006g
Actuator linearity	1.02% of full lift (BFSL)
Set pressure accuracy	+/- 0.5 psi of base pressure
Safe working pressure max.	220 psi / 1520 kPa / 15 bar
Safe inverted pressure max.	180 psi / 1250 kPa / 12.5 bar
Actuator life	550k cycles @ 180°C ambient 800k cycles @ 80°C ambient
Actuator/Valve ratio	2.07:1
Max. spring base pressure	26 psi / 180 kPa / 1.8 bar
Min. spring base pressure	3 psi / 21 kPa / 0.2 bar
Port fittings type	Air: 2x 1/8" NPT top chamber Air: 2x 1/8" NPT lower chamber Liquid Cooling: 2x 1/8" NPT
Port fittings type	Air: 2x 1/8" NPT top chamber Air: 2x 1/8" NPT lower chamber Liquid Cooling: 2x 1/8" NPT

### THERMAL DATA

Max. thermal stress (non-cooled)*	>45min @ 1250°C EGT continuous
Max. thermal stress (h2O cooled)*	>24hr @ 1250°C EGT continuous
Max. ambient/compart ment temp.	260°C / 500°F
Max. actuator temp.	310°C / 590°F

### MATERIAL DATA

Main Body	High temp 347 SS
Diaphragm	Proprietary Silicone w/ nomex
Actuator housing	6061 T6 anodised Al.
Valve Guide	Nitronic 60
Valve	EV8 w/ proprietary plating
V-Band	Heat treated 431 SS w/ 18-8 nut
Weld Flanges	304 Stainless Steel
Springs	17/7 PH Stainless Steel
Beryllium (Be)	0%

### FLOW DATA

Max. Flow	193.6 CFM/5.48m <sup>3</sup> /min @1psidP
Flow Linearity	-18% of full lift (BFSL)

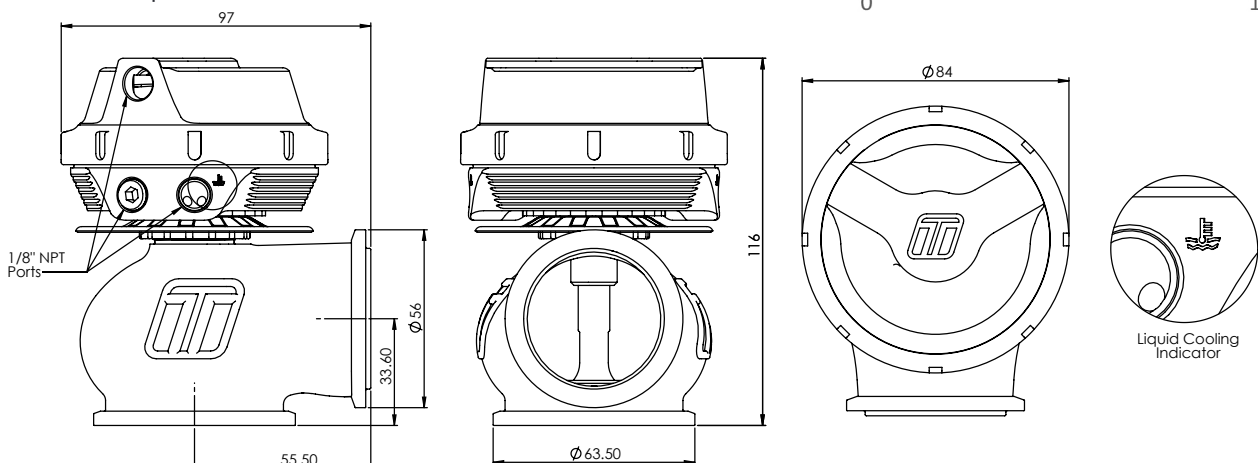
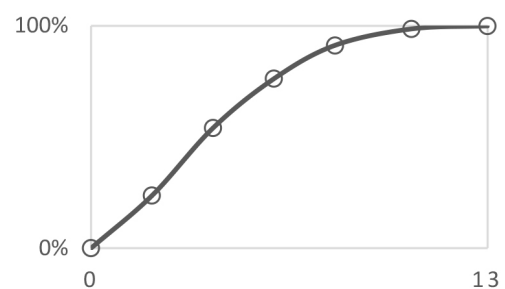

\*Continual source of minimum 1250°C exhaust gas, with no cool down periods for at least 30minutes and no external air cooling on actuator, this is a destructive test that an ICE engine cannot support. Contact tech support for further information.

**INCLUDED IN THE BOX**

- Wastegate unit (pre-assembled with spring as per order)
- SS316 Valve seat
- Inlet V-Band
- Inlet SS304 weld flange
- Outlet V-Band
- Outlet SS304 weld flange
- Collar tool (master/slave)
- 17/7 PH 3, 5, 7, 14 psi spring kit (1x spring installed)
- 4x 1/8" NPT plugs (1x installed) / 2x 1/8" NPT nipples
- Sticker
- Instruction card

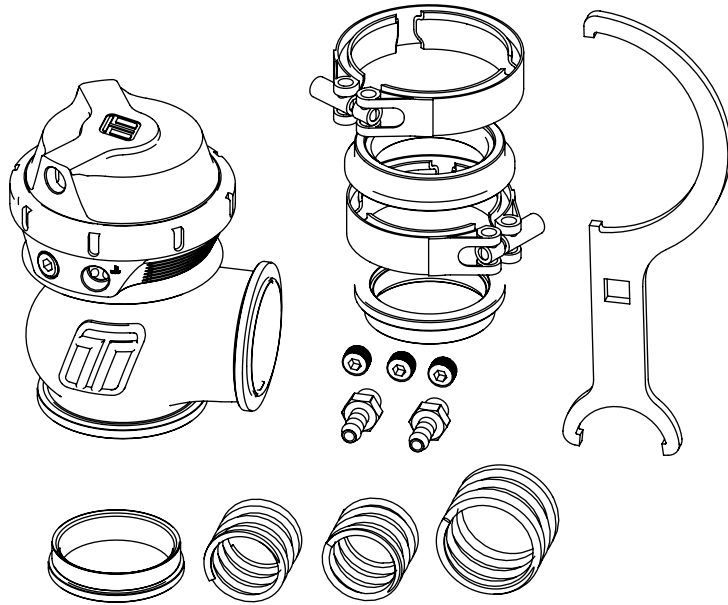

**SPRING DATA**

Wastegate Size	Spring Pressure			
	3psi	5psi	7psi	14psi
WG45/50	Orange	Yellow	Green	Sky Blue

**ORDER DATA**

TS-0553-1001	Gen-V WG45 Hypergate 45 7psi Blue
TS-0553-1002	Gen-V WG45 Hypergate 45 7psi Black
TS-0553-1011	Gen-V WG45 Hypergate 45 14psi Blue
TS-0553-1012	Gen-V WG45 Hypergate 45 14psi Black

**ACCESSORIES**

TS-0553-3001	WG45 Valve seat
TS-0553-3002	WG45 Valve and Guide set
TS-0553-3003	WG45 Inlet V-Band
TS-0553-3004	WG45 Outlet V-Band
TS-0504-3007	WG45 Alloy Inlet Weld Flange
TS-0504-3008	WG45 Alloy Outlet Weld Flange
TS-0550-3024	WG45/50 Sensor Cap Upgrade Kit Black (sensor included)
TS-0550-3025	WG45/50 Sensor Cap Upgrade Kit Blue (sensor included)
TS-0550-3005	WG45/50 Diaphragm Replacement Kit
TS-0550-3014	WG45/50 Actuator Collar Tool

*Refer to website for further accessories*

**INSTALL REQ.**

Inlet Pipe	Suits 47.63mm/1.875" OD
Outlet Pipe	Suits 44.45mm/1.75" OD
Port Tube Min. ID	6mm / 0.236"

	Location	Inner	Inner	Middle	Outer
	Pressure	3psi	5psi	7psi	14psi
Boost Pressure	3psi	•			
	5psi		•		
	7psi			•	
	10psi	•			
	12psi		•	•	
	14psi				•
	17psi	•			•
	19psi		•		•
	21psi			•	•
	24psi	•		•	•
	26psi		•	•	•

**CONFIGURATIONS AVAILABLE**

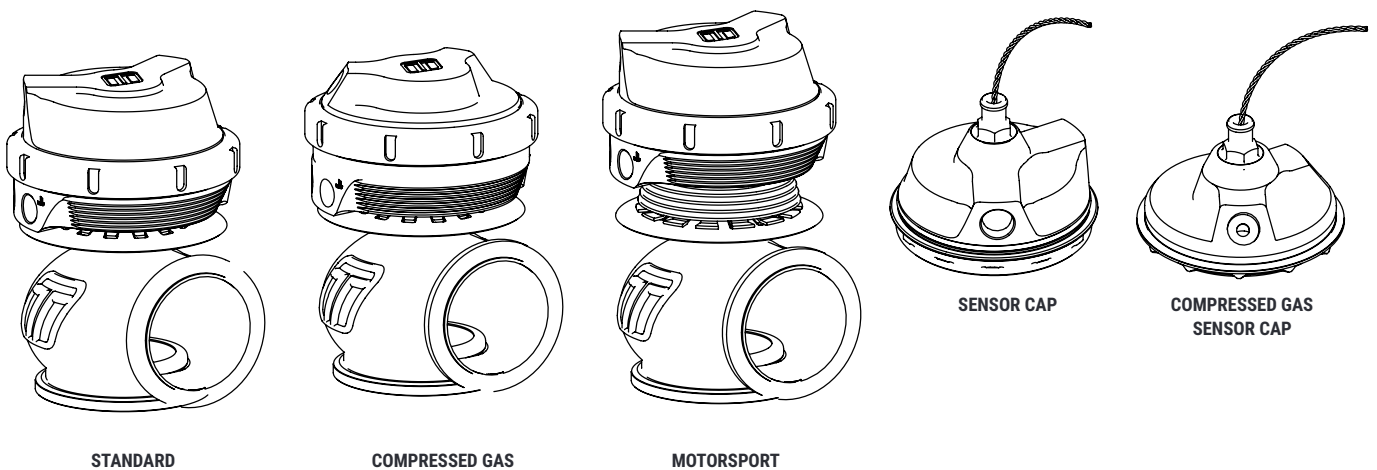

STANDARD

COMPRESSED GAS

MOTORSPORT

SENSOR CAP

COMPRESSED GAS  
SENSOR CAP